

Enclosures can be Factory Modified (Milling, Drilling, Printing etc.)
 Contact Factory mjm@hammondmg.com for quotes
 Solid models of this enclosure available in STEP or IGES.

NOTES	
Purchased assembly includes enclosure, M4x20 lid screws	
Gasket - Pre-formed Silicone Rubber	
Cover screws should be torqued to 5-7.5 lbf.in (50-75 cN.m)	

1550Z101	
PART NUMBERS	
Unfinished	1550Z101
Black Textured Powder Paint - RAL 9011	1550Z101BK

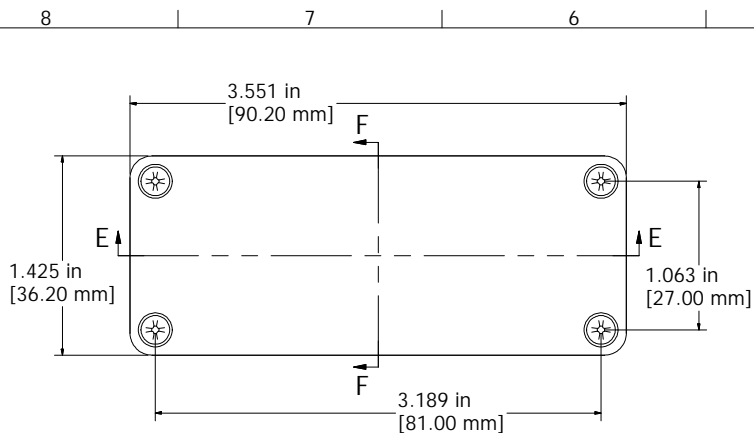



ASSEMBLY

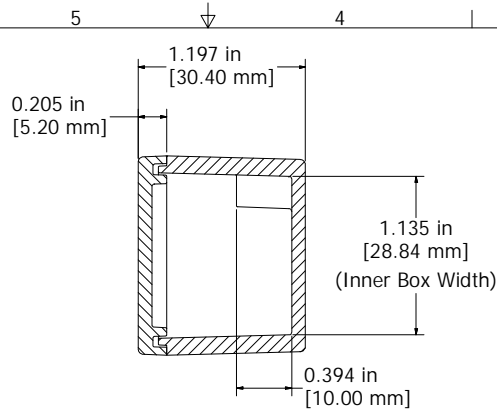

SECTION F-F
End View of Assembly

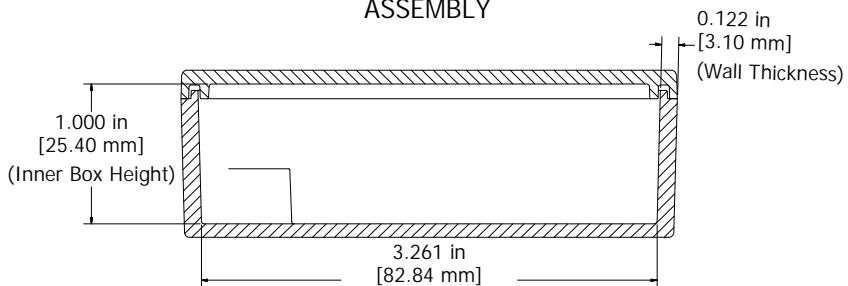
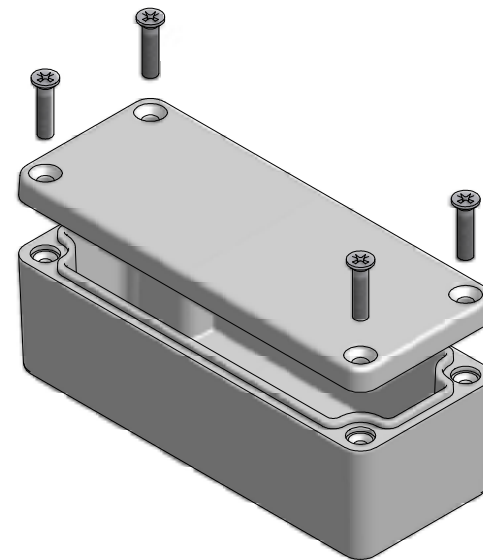

SECTION E-E
Side View of Assembly

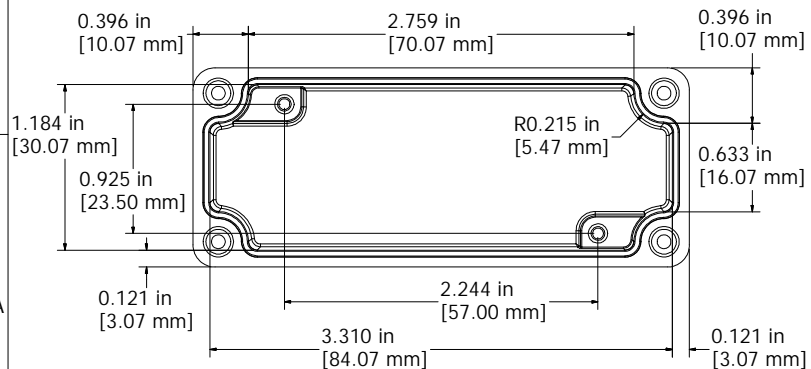

Top View Looking Inside Box

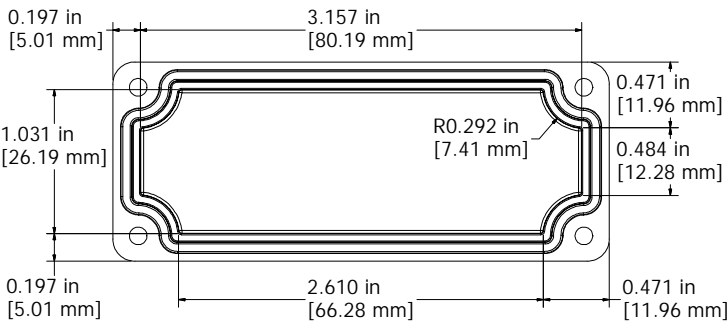

View Looking Inside Lid

Enclosures can be Factory Modified (Milling, Drilling, Printing etc.)
Contact Factory mjm@hammondmg.com for quotes
Solid models of this enclosure available in STEP or IGES.

NOTES

- Purchased assembly includes enclosure, M3x15 lid screws
- Gasket - Pre-formed Silicone Rubber
- Cover screws should be torqued to 5-7.5 lbf.in (50-75 cN.m)

1550Z102

PART NUMBERS

Unfinished	1550Z102
Black Textured Powder Paint - RAL 9011	1550Z102BK

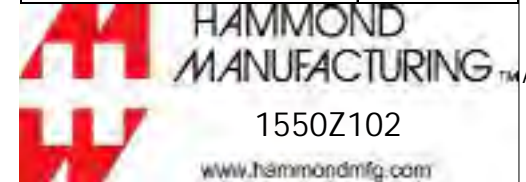

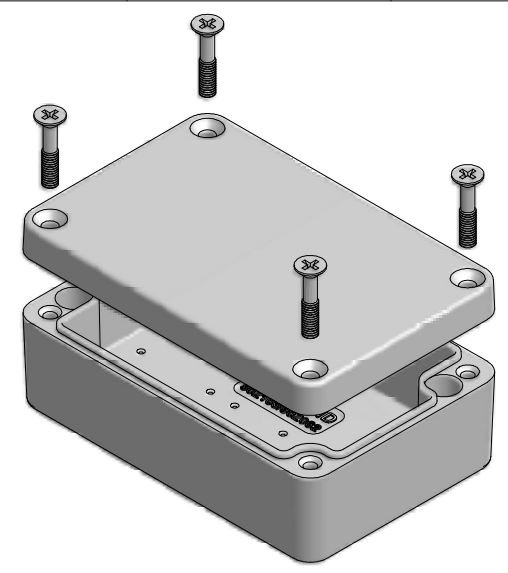
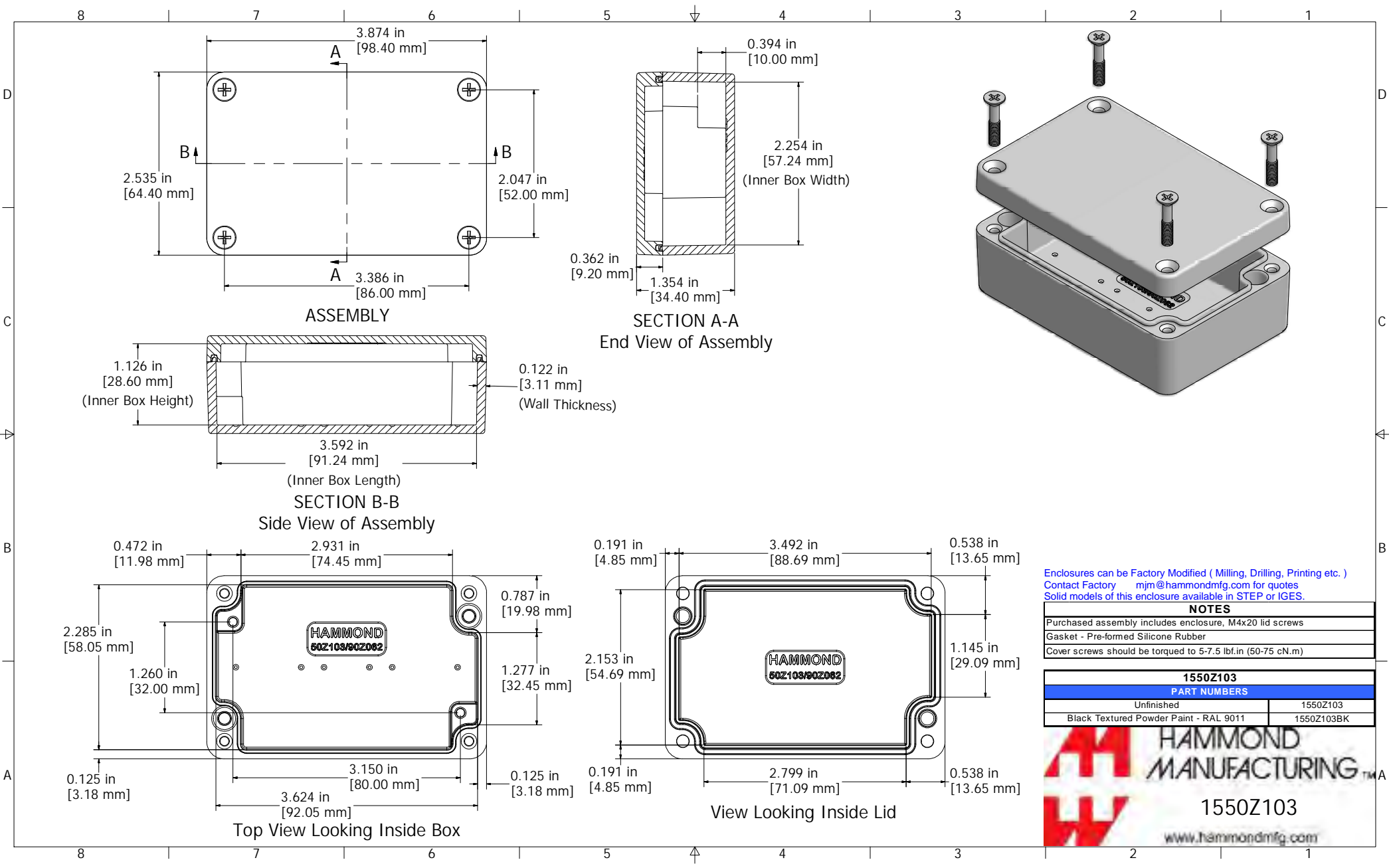

Enclosures can be Factory Modified (Milling, Drilling, Printing etc.)
 Contact Factory mjm@hammondmg.com for quotes
 Solid models of this enclosure available in STEP or IGES.

NOTES	
Purchased assembly includes enclosure, M4x20 lid screws	
Gasket - Pre-formed Silicone Rubber	
Cover screws should be torqued to 5-7.5 lbf.in (50-75 cN.m)	

1550Z103	
PART NUMBERS	
Unfinished	1550Z103
Black Textured Powder Paint - RAL 9011	1550Z103BK



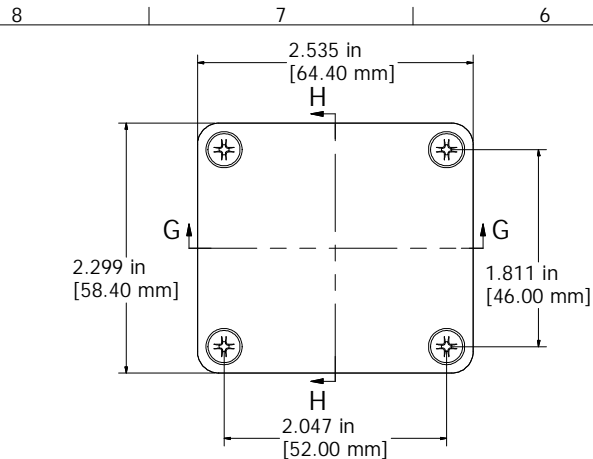

ASSEMBLY

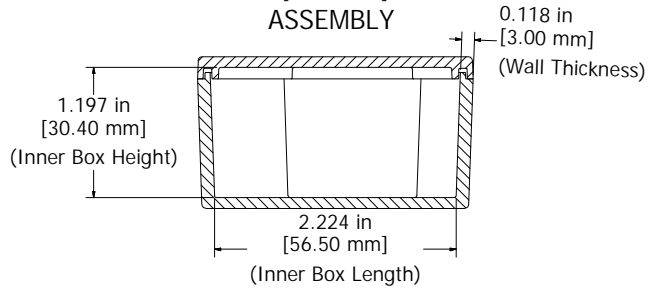

SECTION G-G
Side View of Assembly

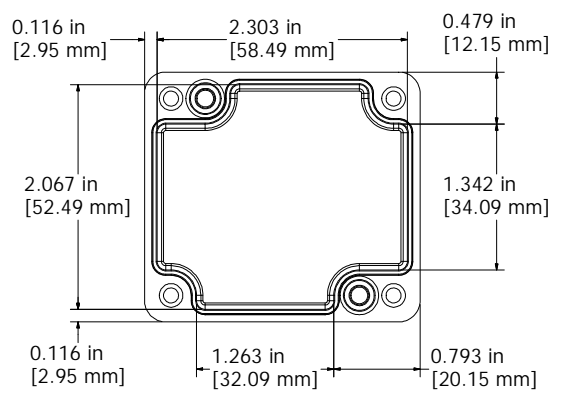

Top View Looking Inside Box

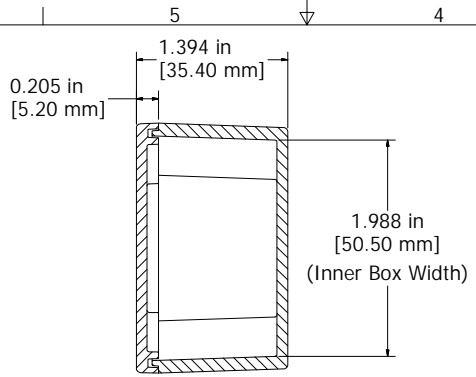

SECTION H-H
End View of Assembly

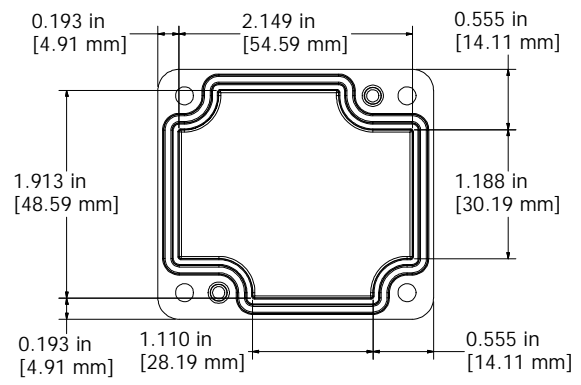

View Looking Inside Lid

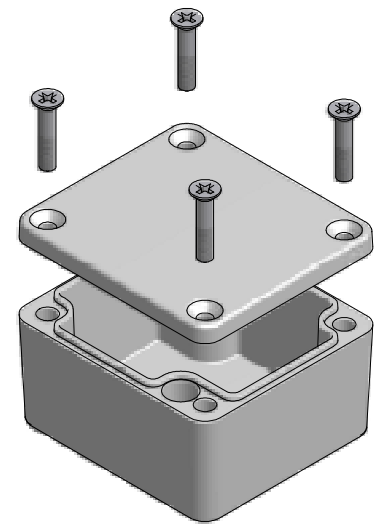

Enclosures can be Factory Modified (Milling, Drilling, Printing etc.)
 Contact Factory mjm@hammondmfg.com for quotes
 Solid models of this enclosure available in STEP or IGES.

NOTES	
Purchased assembly includes enclosure, M4x20 lid screws	
Gasket - Pre-formed Silicone Rubber	
Cover screws should be torqued to 5-7.5 lbf.in (50-75 cN.m)	

1550Z104	
PART NUMBERS	
Unfinished	1550Z104
Black Textured Powder Paint - RAL 9011	1550Z104BK



8 7 6 5 4 3 2 1

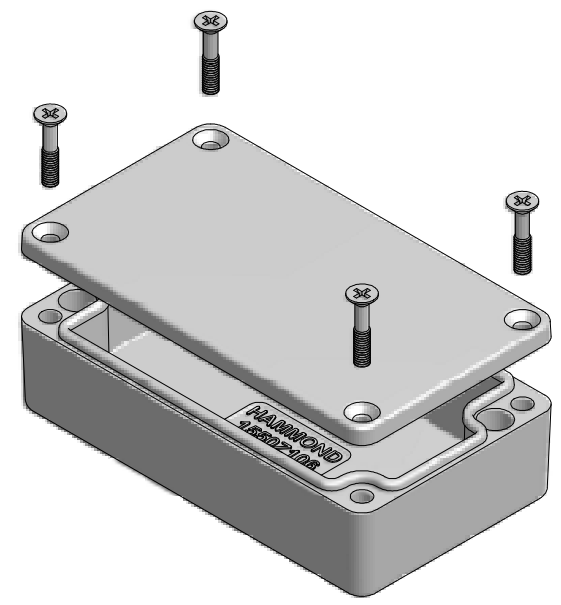
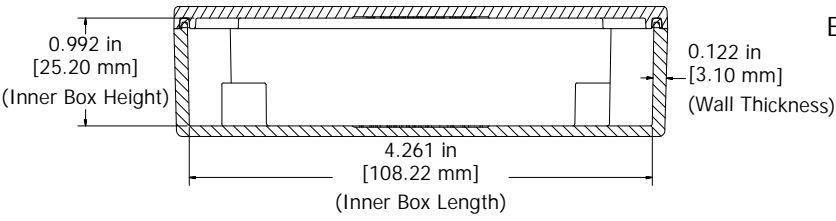
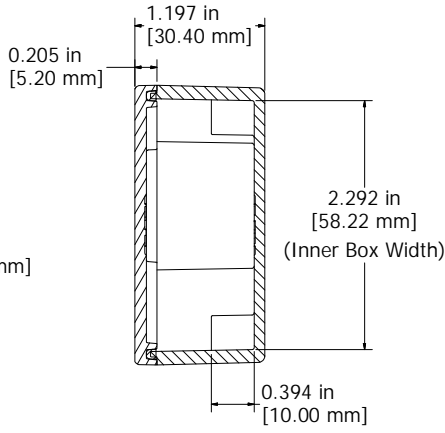
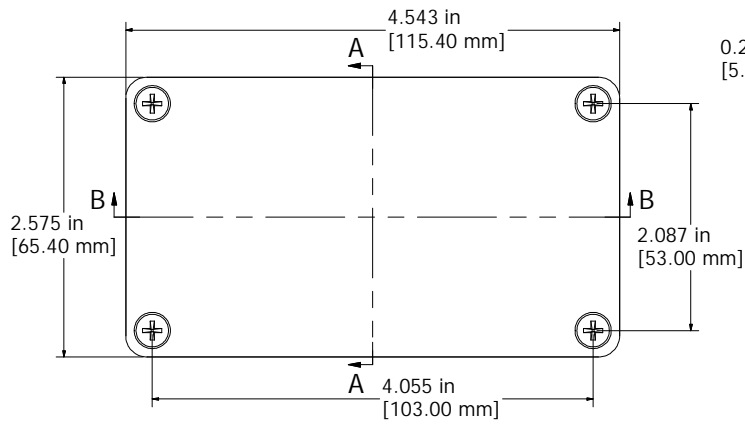

SECTION B-B
Side View of Assembly

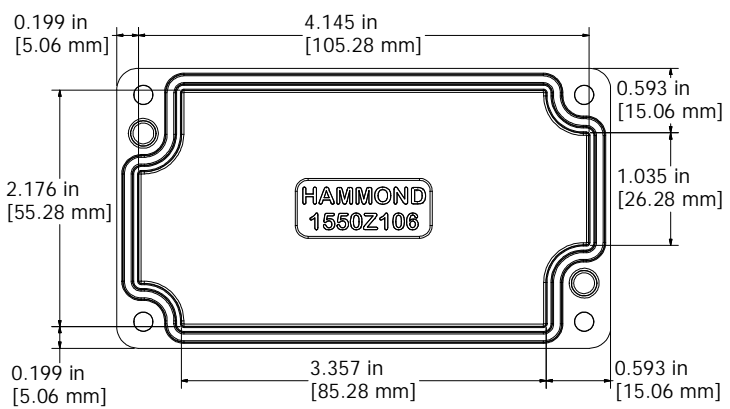
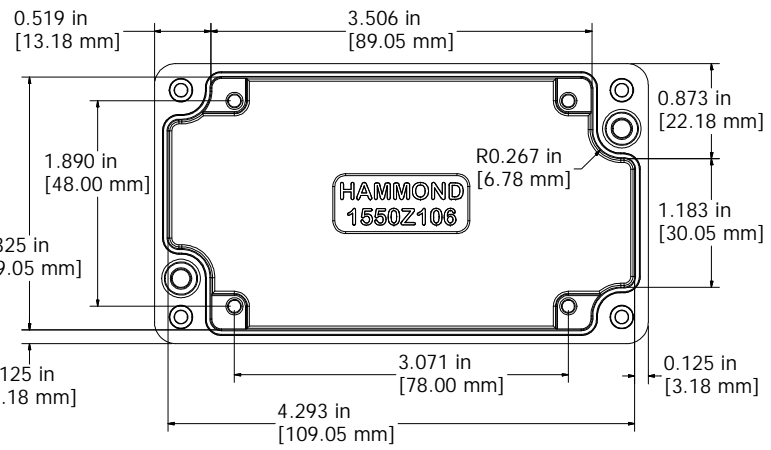

Enclosures can be Factory Modified (Milling, Drilling, Printing etc.)
Contact Factory mjm@hammondmg.com for quotes
Solid models of this enclosure available in STEP or IGES.

NOTES	
Purchased assembly includes enclosure, M4x20 lid screws	
Gasket - Pre-formed Silicone Rubber	
Cover screws should be torqued to 5-7.5 lbf.in (50-75 cN.m)	

1550Z106	
PART NUMBERS	
Unfinished	1550Z106
Black Textured Powder Paint - RAL 9011	1550Z106BK



8 7 6 5 4 3 2 1

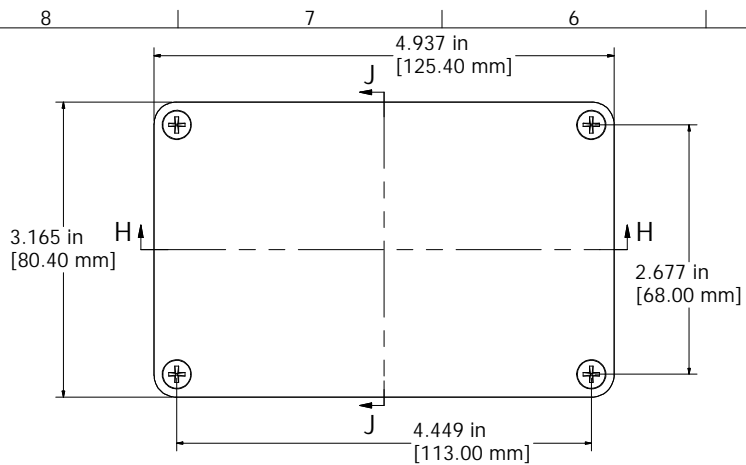

ASSEMBLY

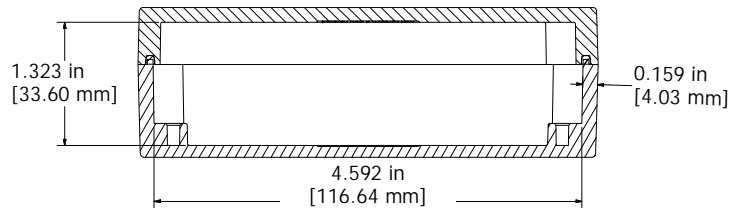

(Inner Box Length)

SECTION H-H

Side View of Assembly

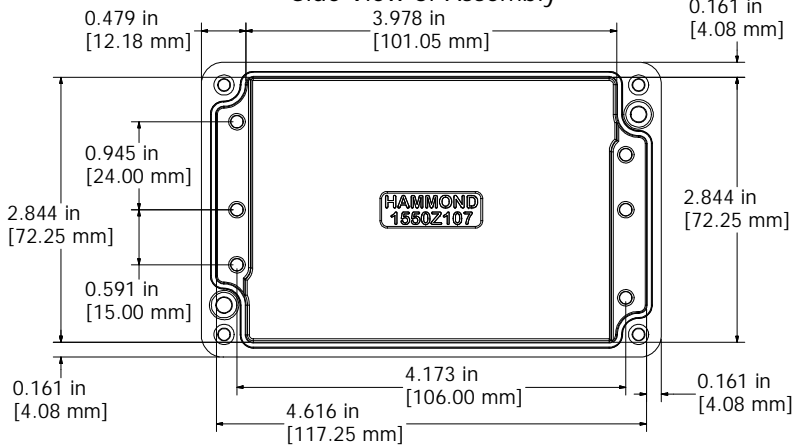

Top View Looking Inside Box

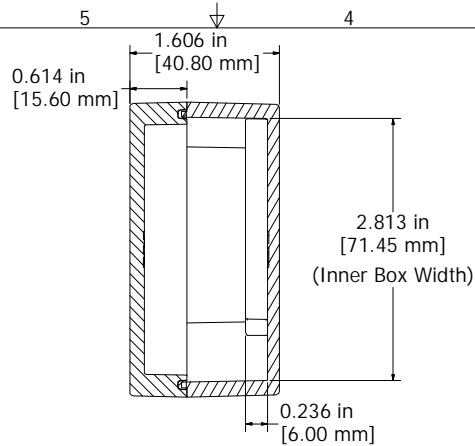

SECTION J-J
End View of Assembly

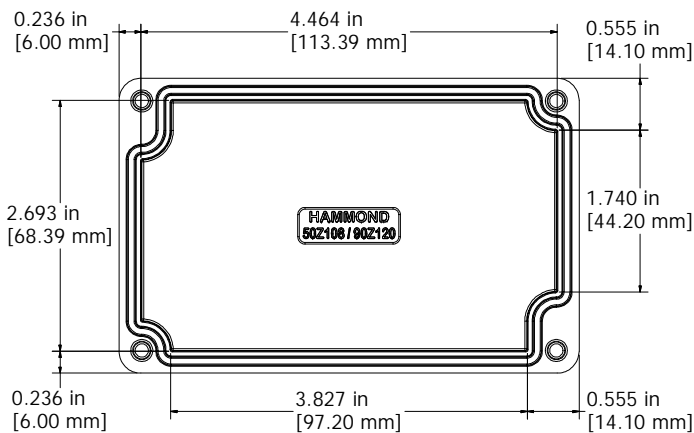
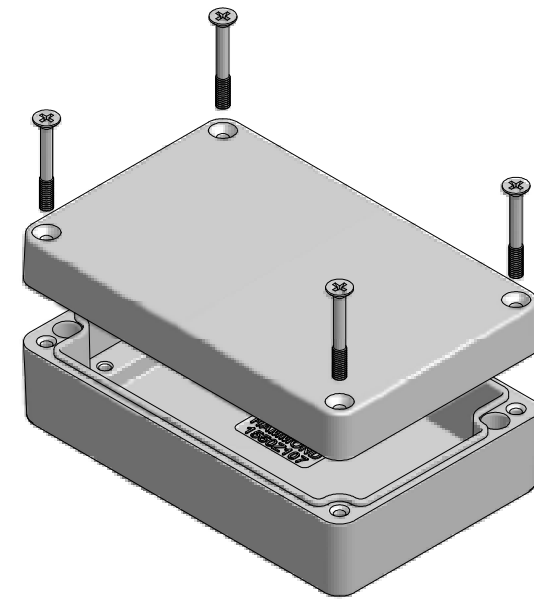

View Looking Inside Lid

Enclosures can be Factory Modified (Milling, Drilling, Printing etc.)
Contact Factory mjm@hammondmg.com for quotes
Solid models of this enclosure available in STEP or IGES.

NOTES

- Purchased assembly includes enclosure, M4x25 lid screws
- Gasket - Pre-formed Silicone Rubber
- Cover screws should be torqued to 5-7.5 lbf.in (50-75 cN.m)

1550Z107

PART NUMBERS

Unfinished	1550Z107
Black Textured Powder Paint - RAL 9011	1550Z107BK

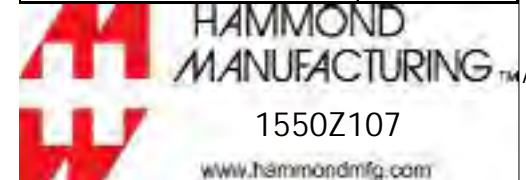

8 7 6 5 4 3 2 1

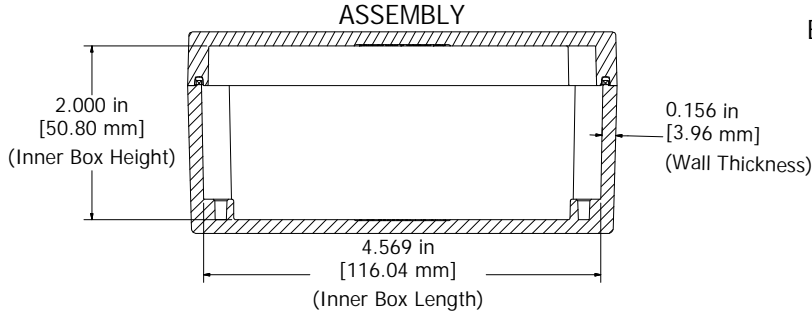
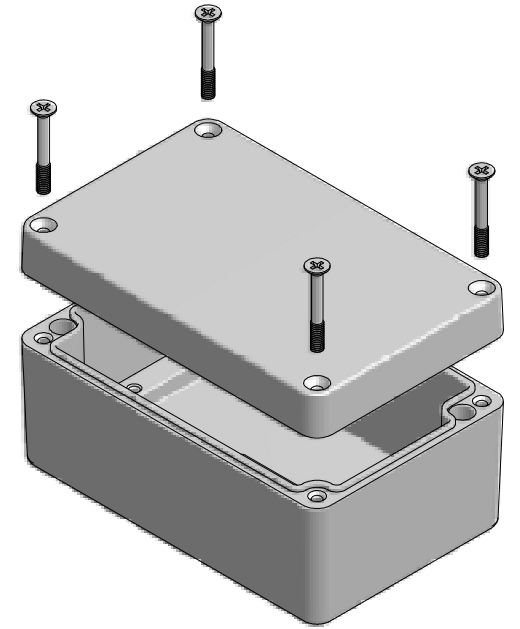
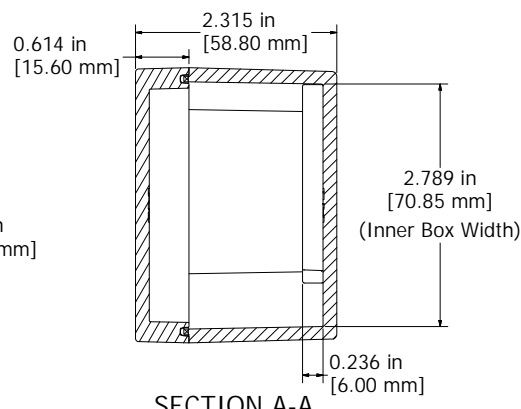
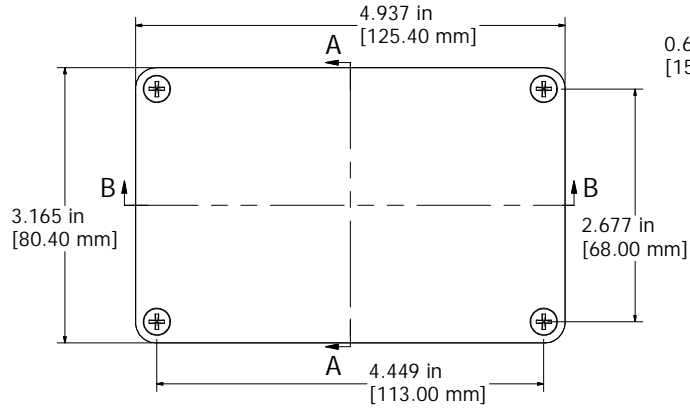

SECTION B-B
Side View of Assembly

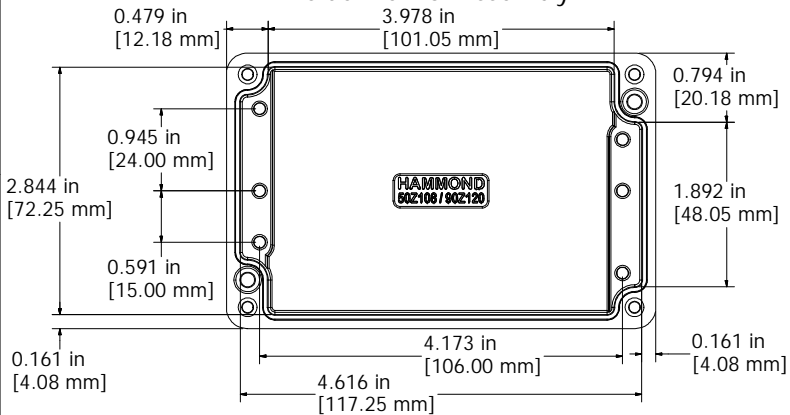

Top View Looking Inside Box

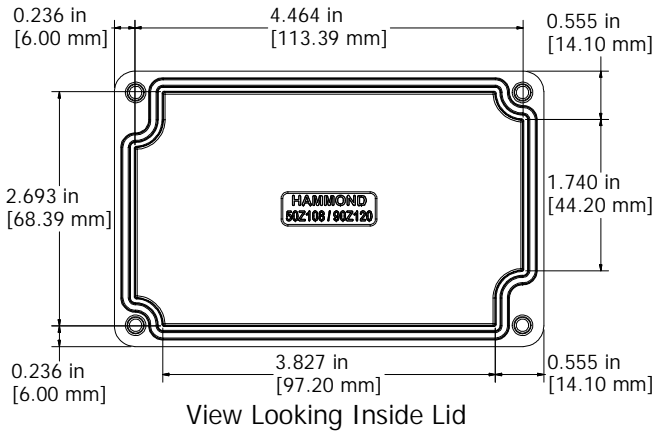

View Looking Inside Lid

Enclosures can be Factory Modified (Milling, Drilling, Printing etc.)
Contact Factory mjm@hammondmg.com for quotes
Solid models of this enclosure available in STEP or IGES.

NOTES

- Purchased assembly includes enclosure, M4x25 lid screws
- Gasket - Pre-formed Silicone Rubber
- Cover screws should be torqued to 5-7.5 lbf.in (50-75 cN.m)

1550Z108	
PART NUMBERS	
Unfinished	1550Z108
Black Textured Powder Paint - RAL 9011	1550Z108BK



8 7 6 5 4 3 2 1

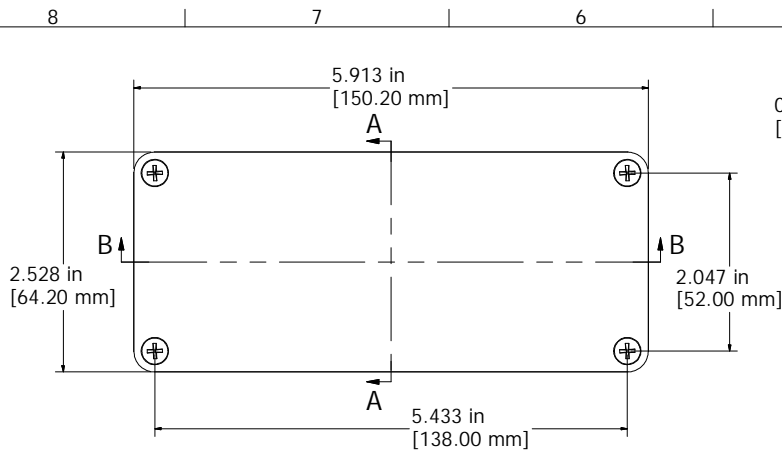

ASSEMBLY

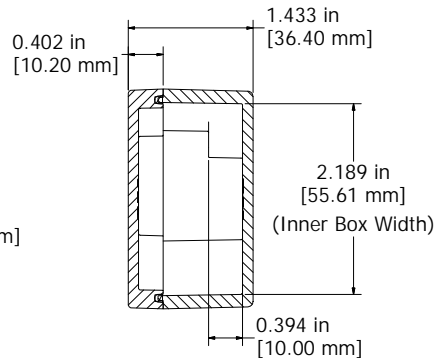

SECTION A-A
End View of Assembly

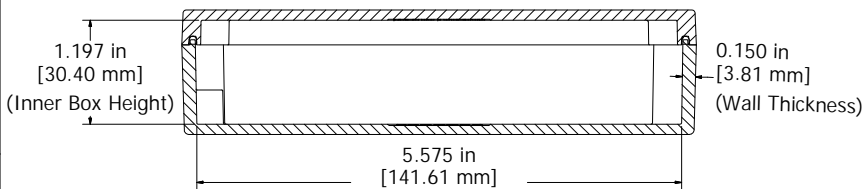
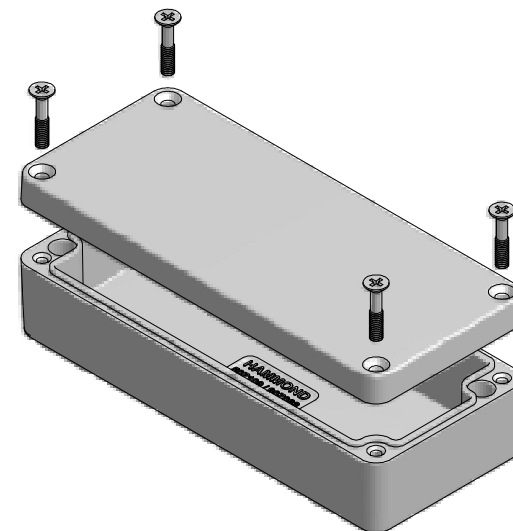

SECTION B-B
Side View of Assembly

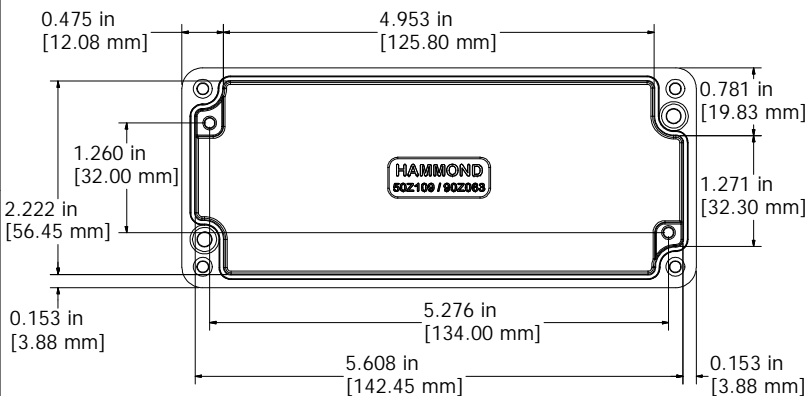

Top View Looking Inside Box

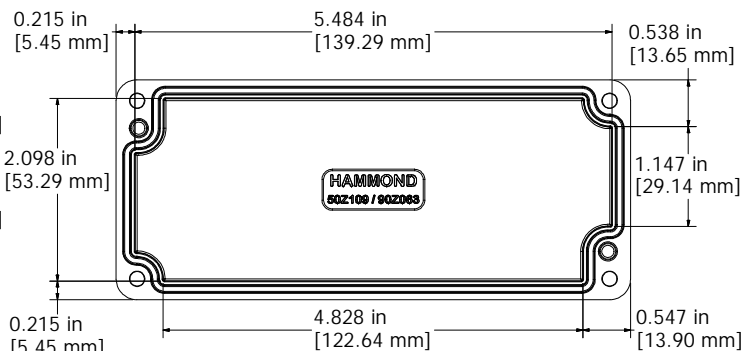

View Looking Inside Lid

Enclosures can be Factory Modified (Milling, Drilling, Printing etc.)
Contact Factory mjm@hammondmg.com for quotes
Solid models of this enclosure available in STEP or IGES.

NOTES

- Purchased assembly includes enclosure, M4x20 lid screws
- Gasket - Pre-formed Silicone Rubber
- Cover screws should be torqued to 5-7.5 lbf.in (50-75 cN.m)

1550Z109	
PART NUMBERS	
Unfinished	1550Z109
Black Textured Powder Paint - RAL 9011	1550Z109BK

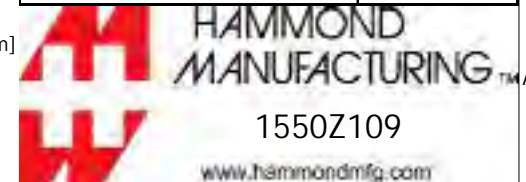

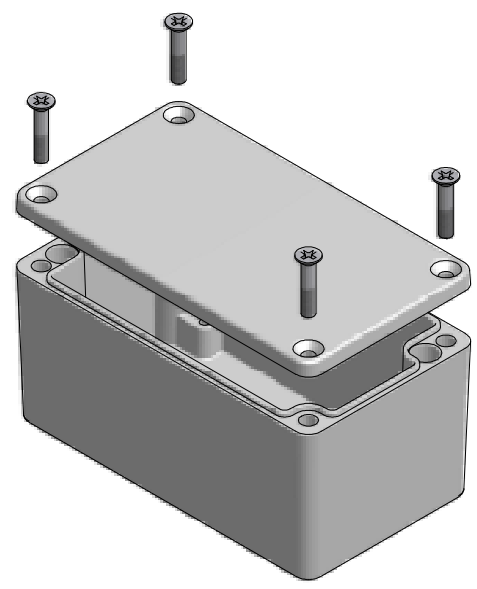
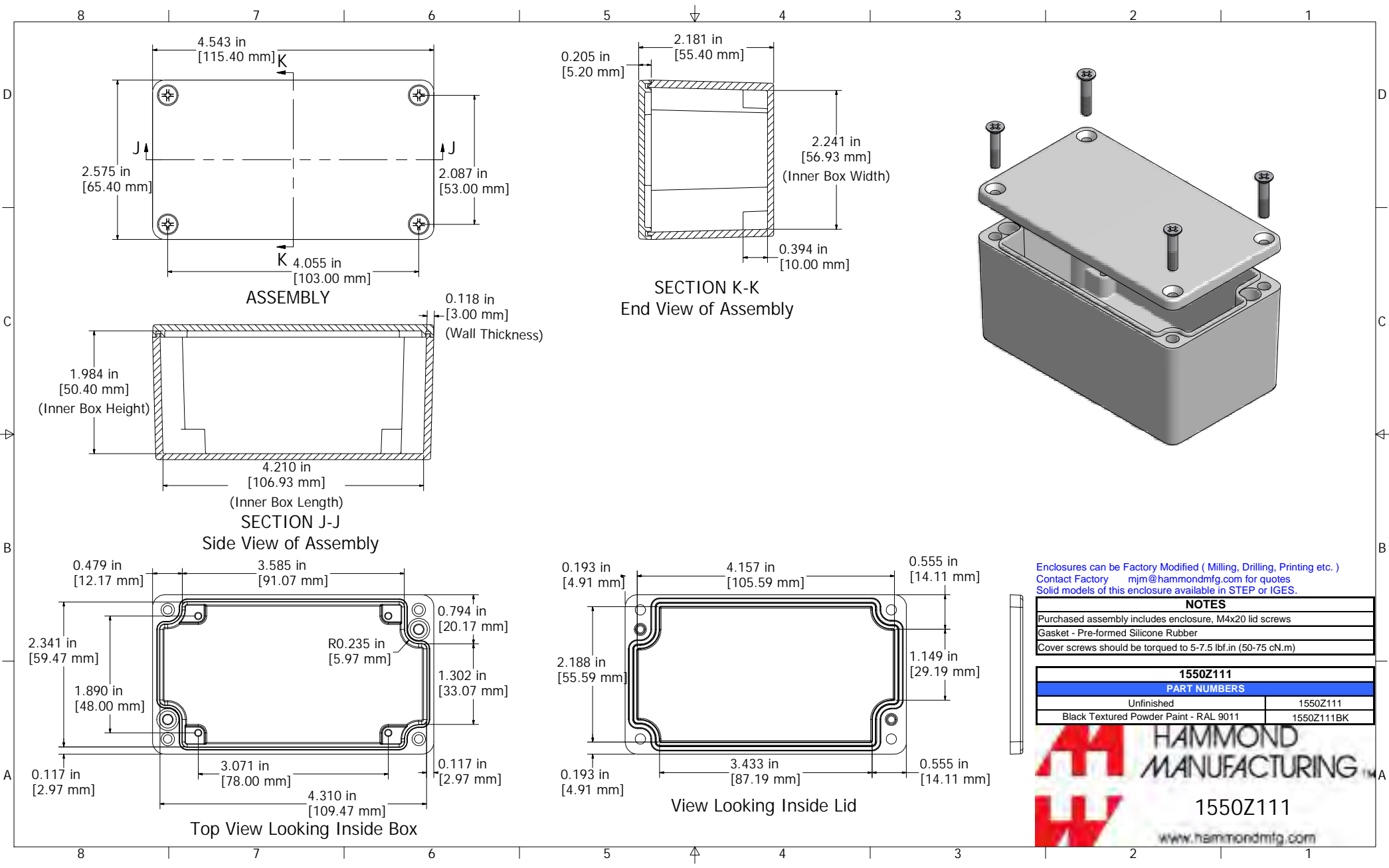

Enclosures can be Factory Modified (Milling, Drilling, Printing etc.)
 Contact Factory mjm@hammondmgf.com for quotes
 Solid models of this enclosure available in STEP or IGES.

NOTES	
Purchased assembly includes enclosure, M4x20 lid screws	
Gasket - Pre-formed Silicone Rubber	
Cover screws should be torqued to 5-7.5 lbf.in (50-75 cN.m)	

1550Z111	
PART NUMBERS	
Unfinished	1550Z111
Black Textured Powder Paint - RAL 9011	1550Z111BK



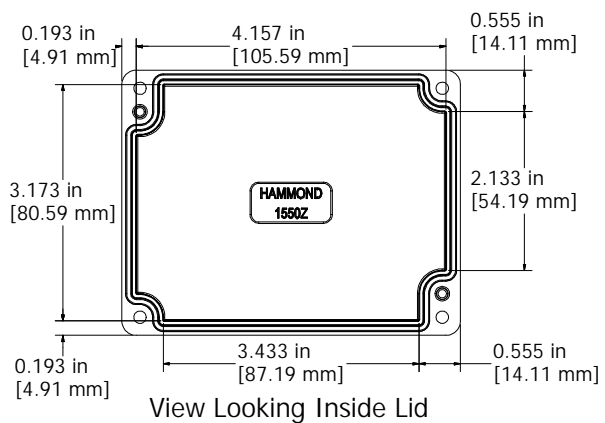
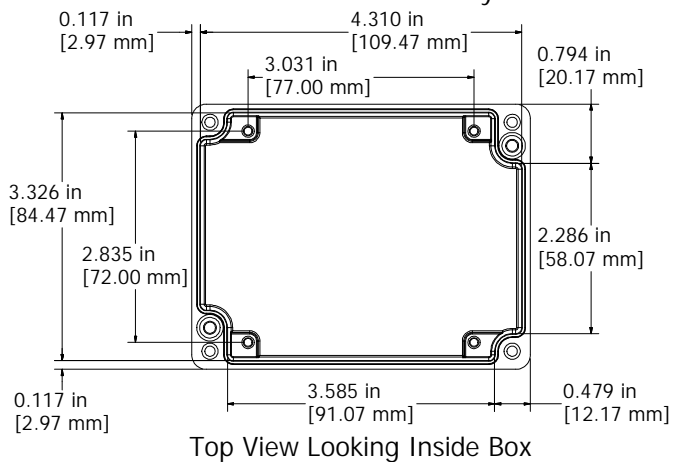
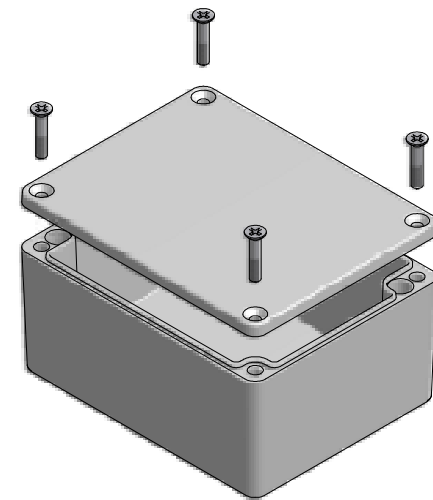
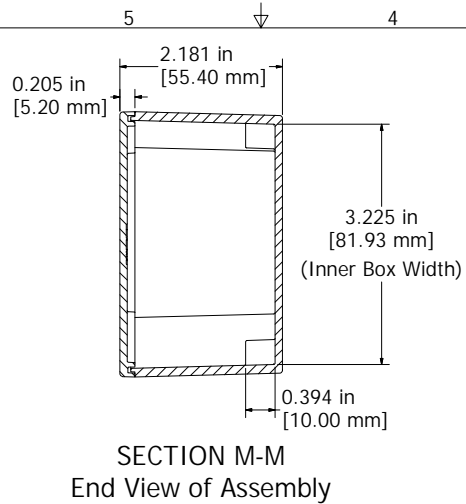
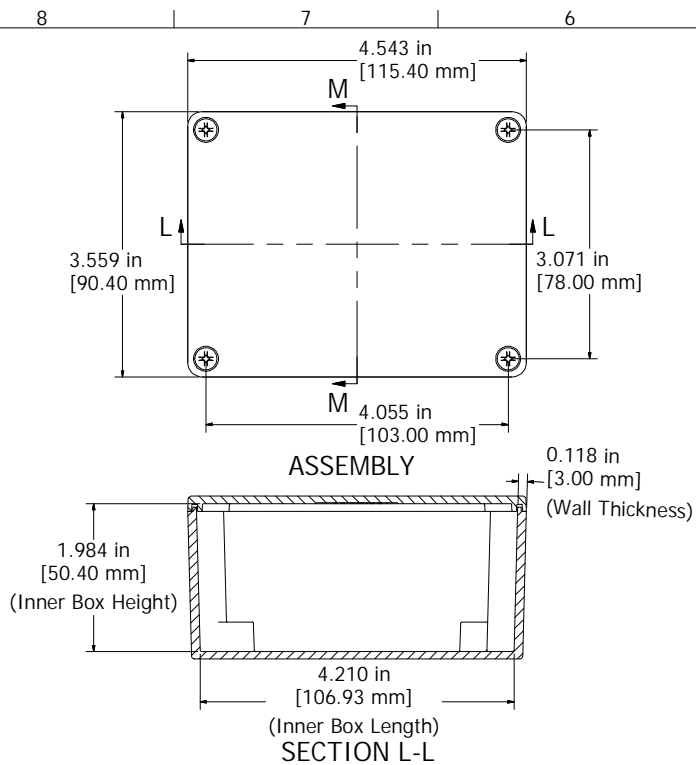

Enclosures can be Factory Modified (Milling, Drilling, Printing etc.)
 Contact Factory mjm@hammondmfg.com for quotes
 Solid models of this enclosure available in STEP or IGES.

NOTES	
Purchased assembly includes enclosure, M4x20 lid screws	
Gasket - Pre-formed Silicone Rubber	
Cover screws should be torqued to 5-7.5 lbf.in (50-75 cN.m)	

1550Z113	
PART NUMBERS	
Unfinished	1550Z113
Black Textured Powder Paint - RAL 9011	1550Z113BK



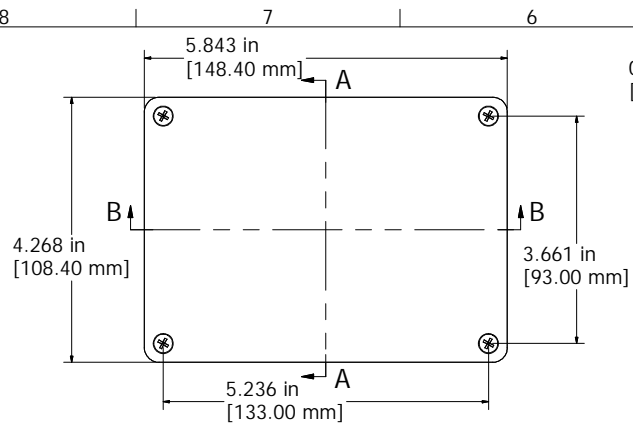

ASSEMBLY

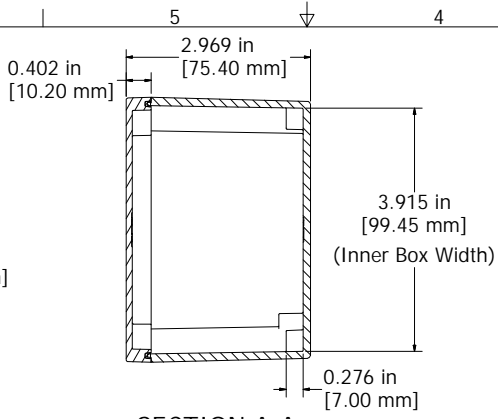

SECTION A-A
End View of Assembly

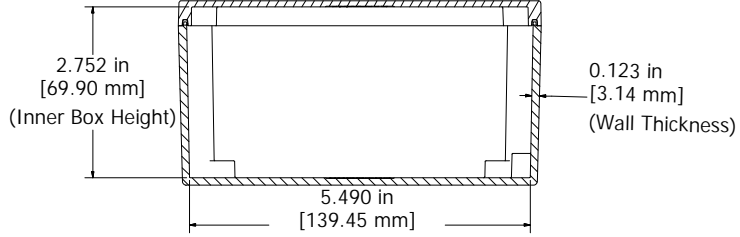
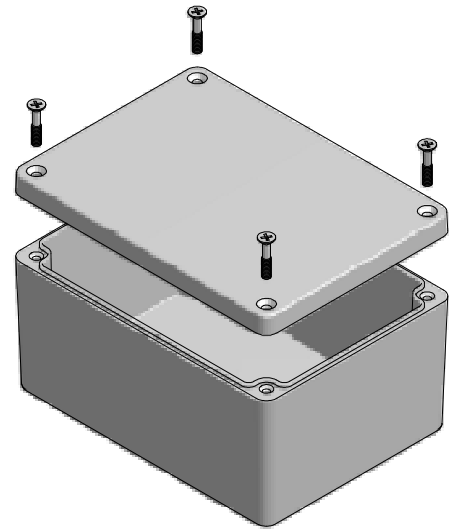

SECTION B-B
Side View of Assembly

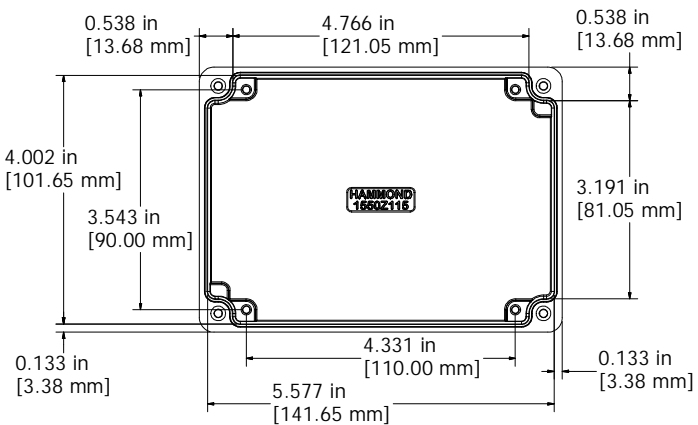

Top View Looking Inside Box

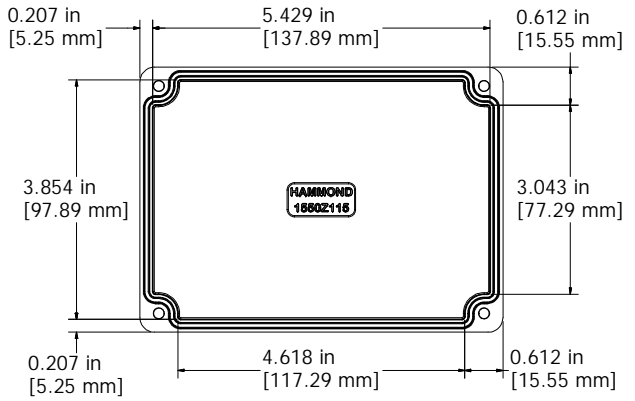

View Looking Inside Box

Enclosures can be Factory Modified (Milling, Drilling, Printing etc.)
 Contact Factory mjm@hammondmfg.com for quotes
 Solid models of this enclosure available in STEP or IGES.

NOTES	
Purchased assembly includes enclosure, M4x20 lid screws	
Gasket - Pre-formed Silicone Rubber	
Cover screws should be torqued to 5-7.5 lbf.in (50-75 cN.m)	

1550Z115	
PART NUMBERS	
Unfinished	1550Z115
Black Textured Powder Paint - RAL 9011	1550Z115BK



8 7 6 5 4 3 2 1

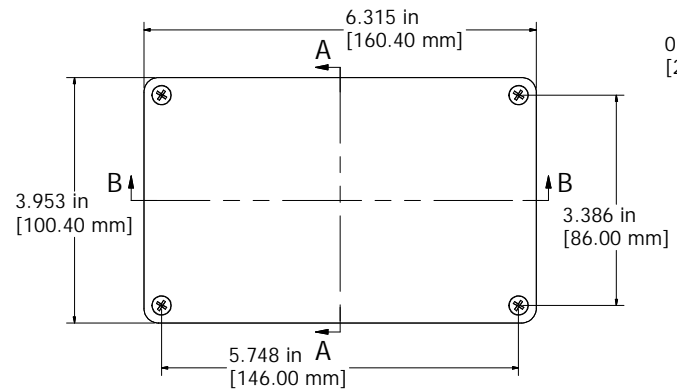

ASSEMBLY

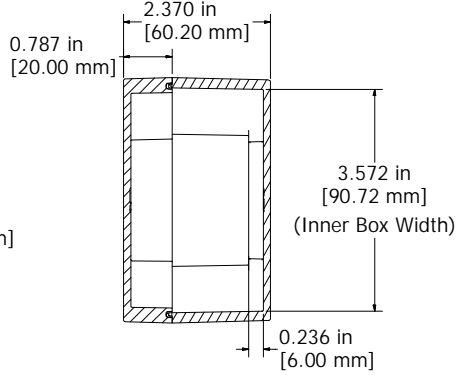

SECTION A-A
End View of Assembly

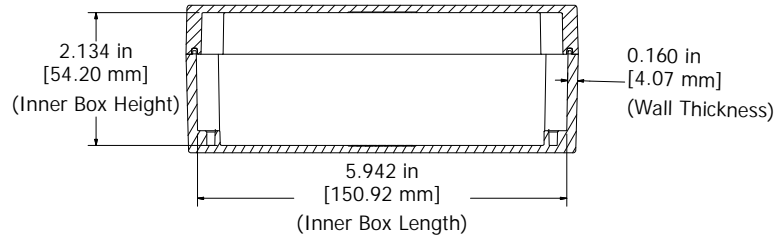

SECTION B-B
Side View of Assembly

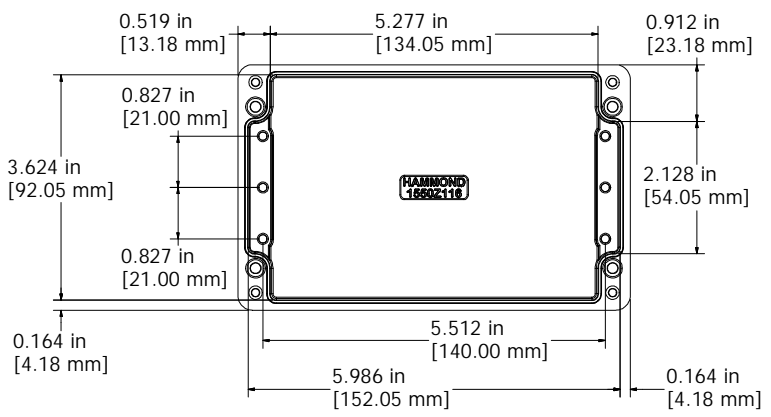
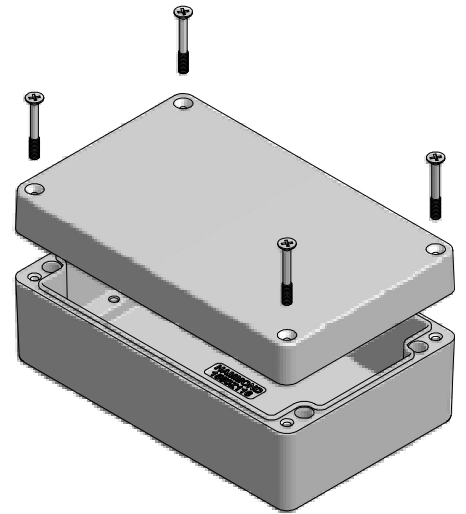

Top View Looking Inside Box

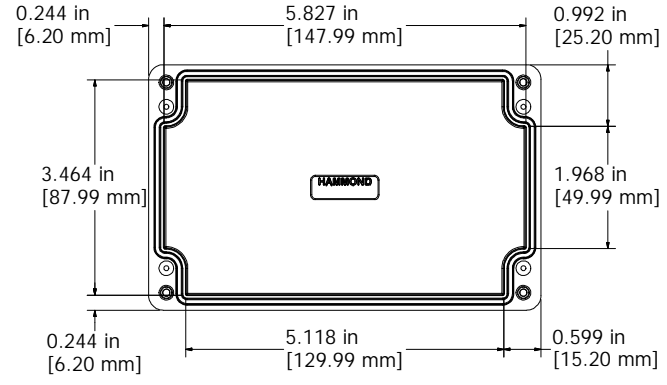

View Looking Inside Lid

Enclosures can be Factory Modified (Milling, Drilling, Printing etc.)
Contact Factory mjm@hammondmfg.com for quotes
Solid models of this enclosure available in STEP or IGES.

NOTES	
Purchased assembly includes enclosure, M4x30 lid screws	
Gasket - Pre-formed Silicone Rubber	
Cover screws should be torqued to 5-7.5 lbf.in (50-75 cN.m)	

1550Z116	
PART NUMBERS	
Unfinished	1550Z116
Black Textured Powder Paint - RAL 9011	1550Z116BK



8 7 6 5 4 3 2 1

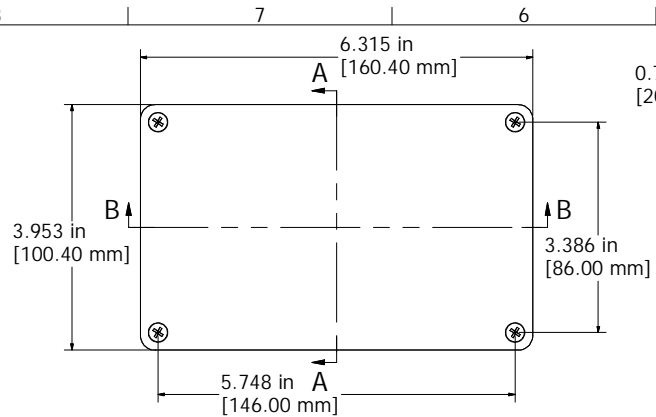

ASSEMBLY

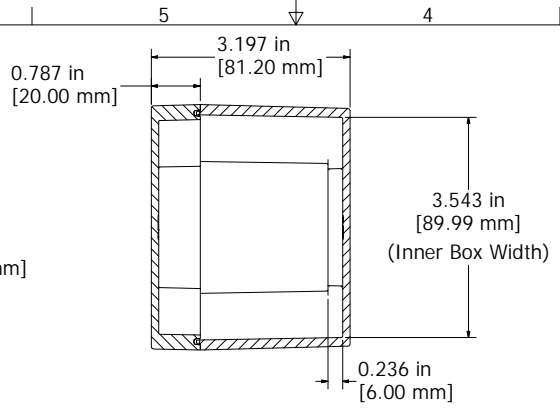

SECTION A-A
End View of Assembly

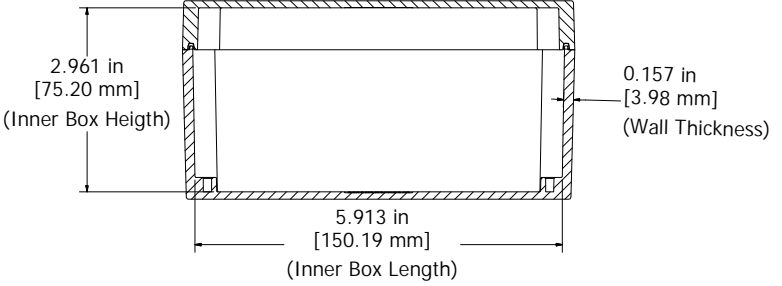

SECTION B-B
Side View of Assembly

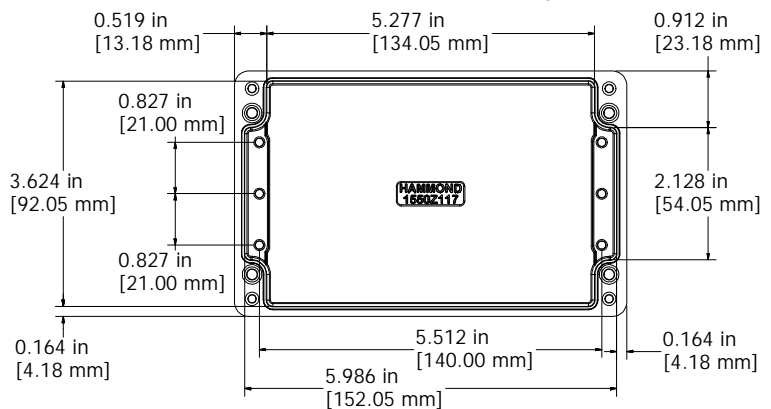
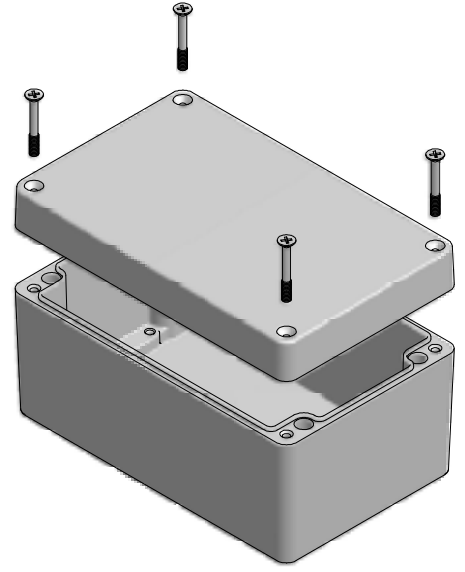

Top View Looking Inside Box

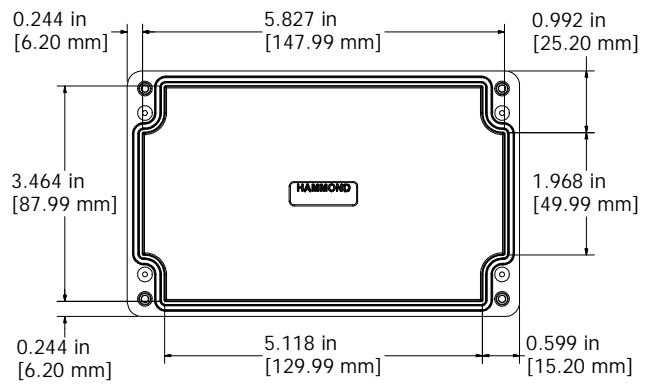

View Looking Inside Lid

Enclosures can be Factory Modified (Milling, Drilling, Printing etc.)
 Contact Factory mjm@hammondmfg.com for quotes
 Solid models of this enclosure available in STEP or IGES.

NOTES	
Purchased assembly includes enclosure, M4x30 lid screws	
Gasket - Pre-formed Silicone Rubber	
Cover screws should be torqued to 5-7.5 lbf.in (50-75 cN.m)	

1550Z117	
PART NUMBERS	
Unfinished	1550Z117
Black Textured Powder Paint - RAL 9011	1550Z117BK



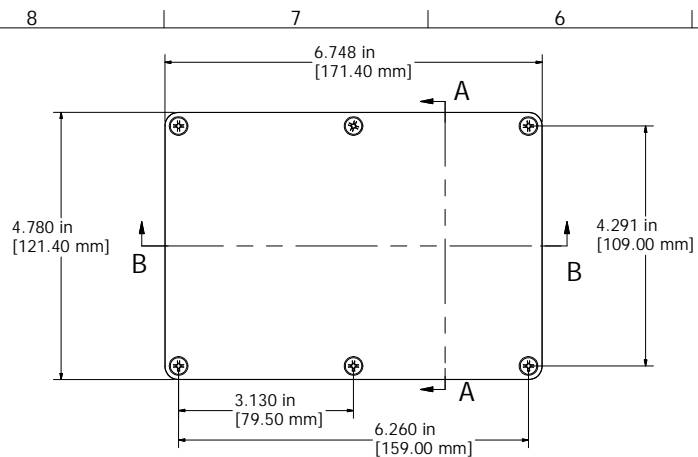

ASSEMBLY

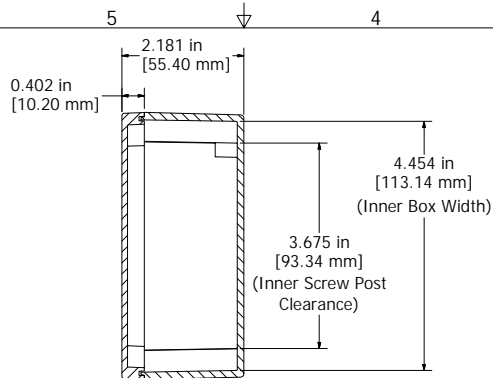

SECTION A-A
End View of Assembly

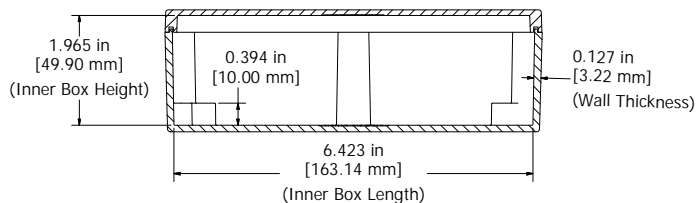
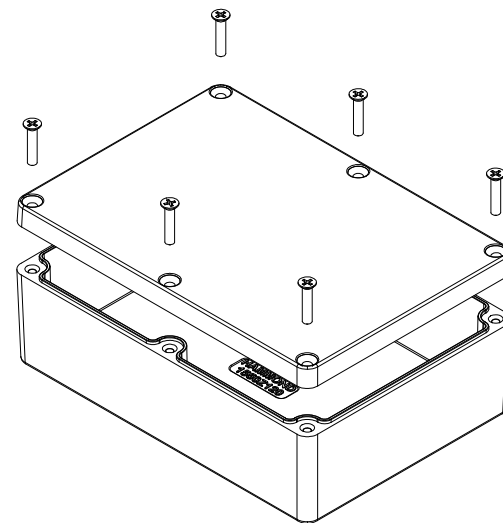

SECTION B-B
Side View of Assembly

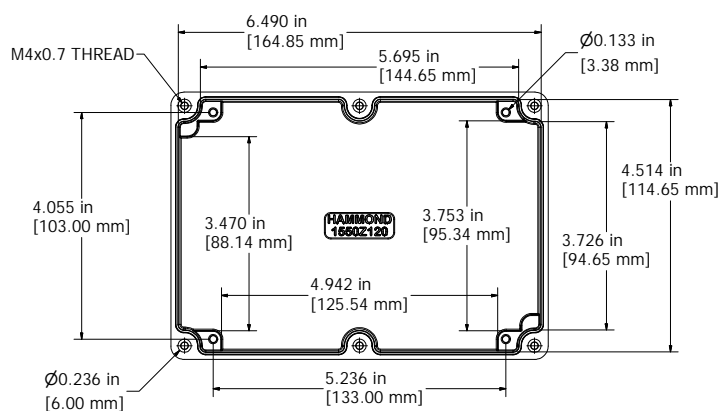

Top View Looking Inside Box

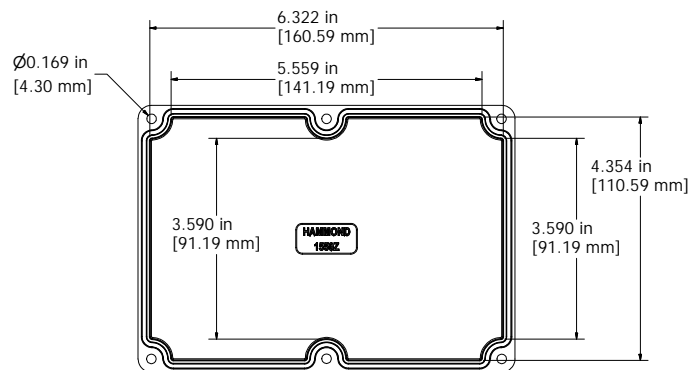

View Looking Inside Lid

Enclosures can be Factory Modified (Milling, Drilling, Printing etc.)
Contact Factory mjm@hammondmfg.com for quotes
Solid models of this enclosure available in STEP or IGES.

NOTES	
Purchased assembly includes enclosure, M4x20 lid screws	
Gasket - Pre-formed Silicone Rubber	
Cover screws should be torqued to 5-7.5 lbf.in (50-75 cN.m)	

1550Z120	
PART NUMBERS	
Unfinished	1550Z120
Black Textured Powder Paint - RAL 9011	1550Z120BK



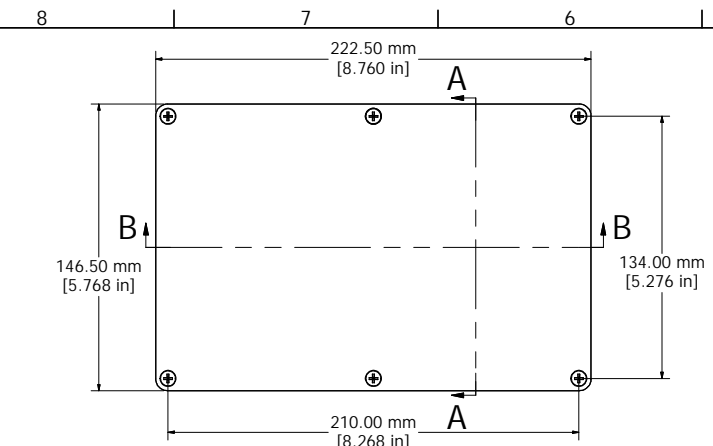

ASSEMBLY

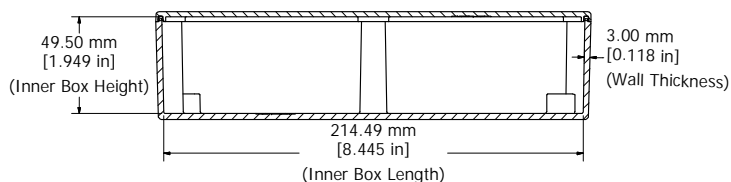

SECTION B-B
Side View of Assembly

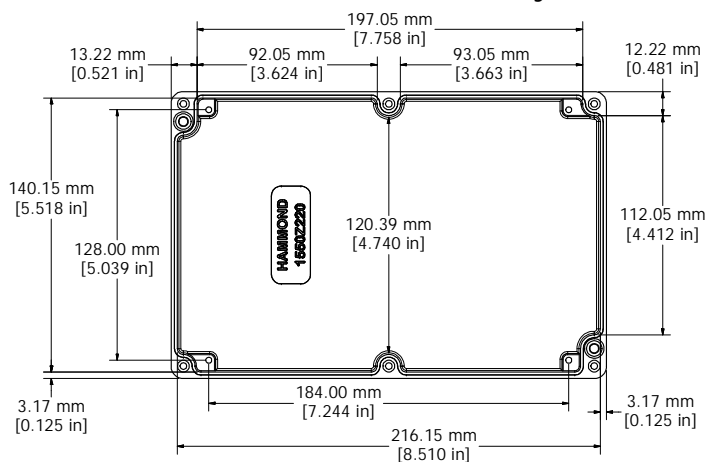

Top View Looking Inside Box

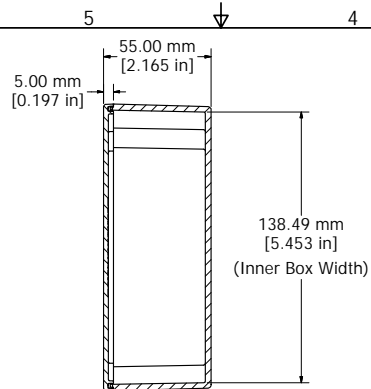

SECTION A-A
End View of Assembly

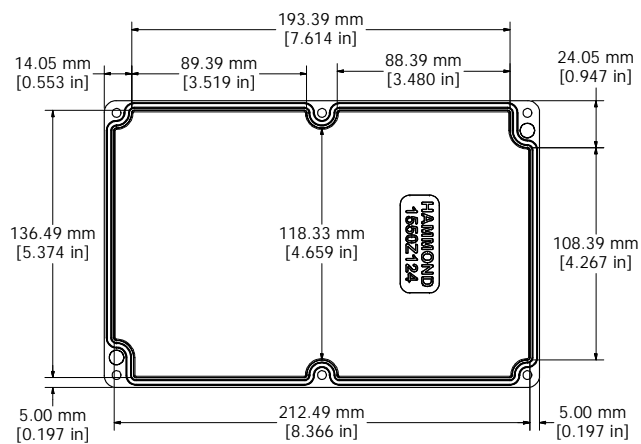
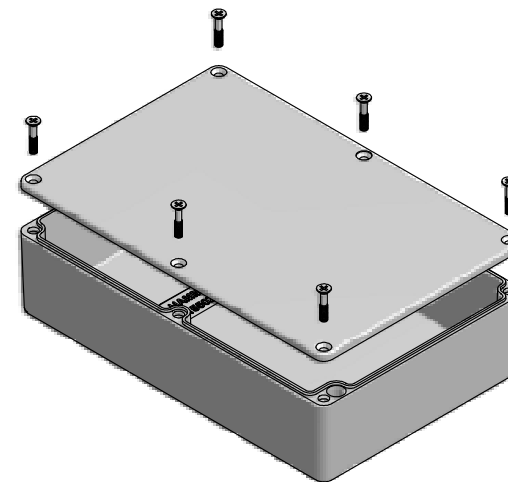

View Looking Inside Lid

Enclosures can be Factory Modified (Milling, Drilling, Printing etc.)
Contact Factory mjm@hammondmfg.com for quotes
Solid models of this enclosure available in STEP or IGES.

NOTES

- Purchased assembly includes enclosure, M4x20 lid screws
- Gasket - Pre-formed Silicone Rubber
- Cover screws should be torqued to 5-7.5 lbf.in (50-75 cN.m)

1550Z124	
PART NUMBERS	
Unfinished	1550Z124
Black Textured Powder Paint - RAL 9011	1550Z124BK



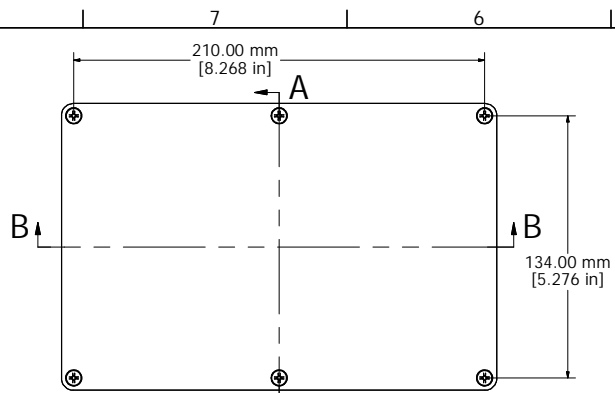

ASSEMBLY

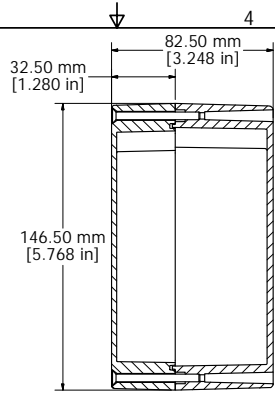

SECTION A-A
End View of Assembly

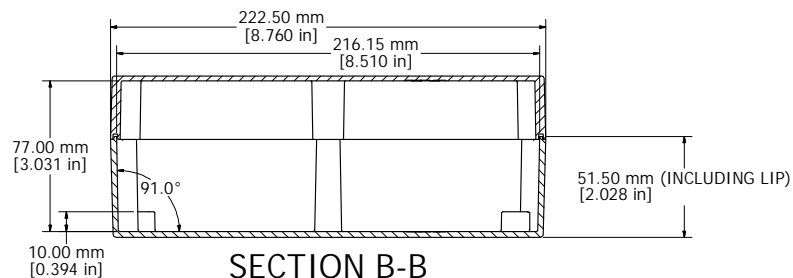
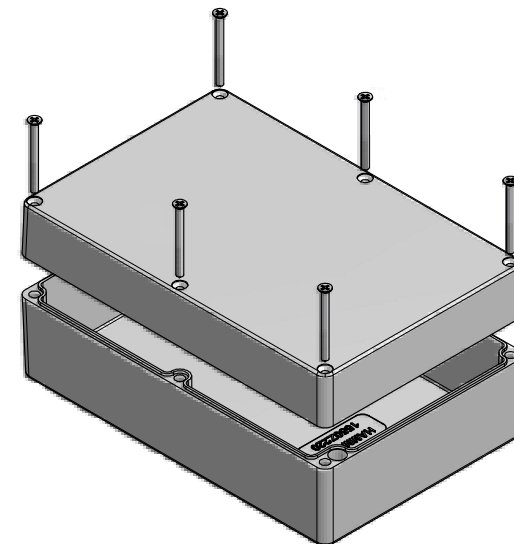

SECTION B-B
Side View of Assembly

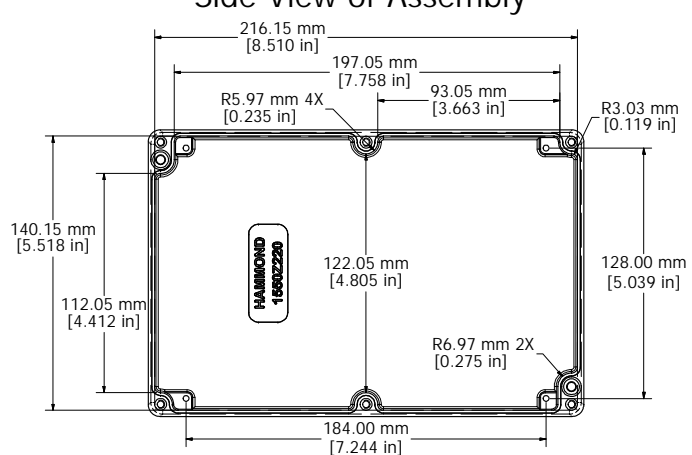

Top View Looking Inside Box

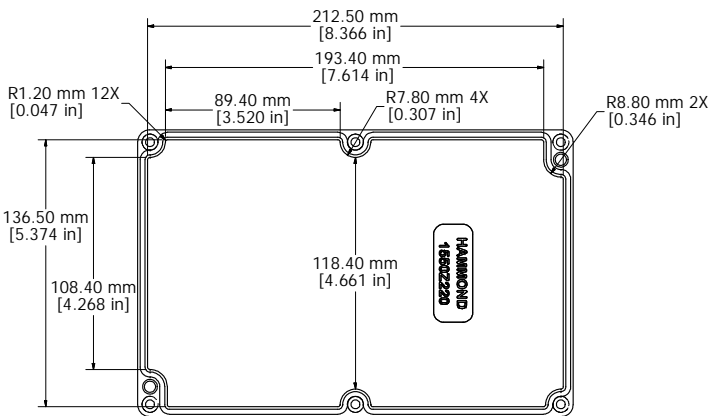

View Looking Inside Lid

Enclosures can be Factory Modified (Milling, Drilling, Printing etc.)
Contact Factory mjm@hammondmg.com for quotes
Solid models of this enclosure available in STEP or IGES.

NOTES	
Purchased assembly includes enclosure, M4x45 lid screws	
Gasket - Pre-formed Silicone Rubber	
Cover screws should be torqued to 5-7.5 lbf.in (50-75 cN.m)	

1550Z220	
PART NUMBERS	
Unfinished	1550Z220
Black Textured Powder Paint - RAL 9011	1550Z220BK



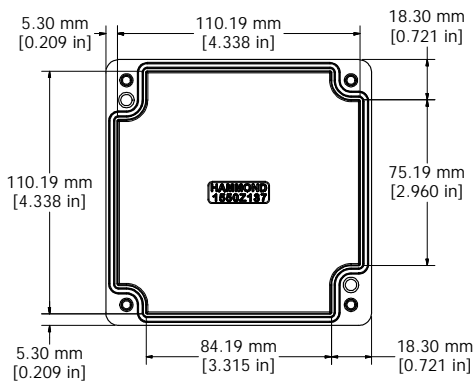
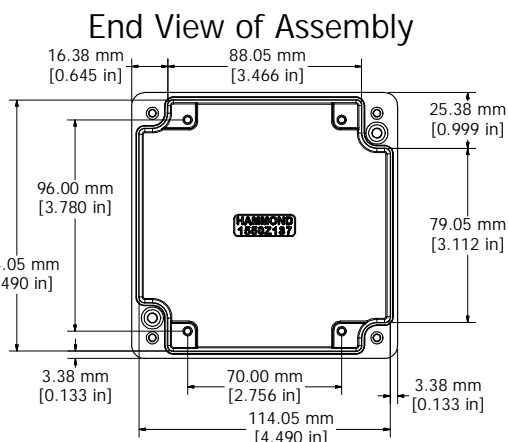
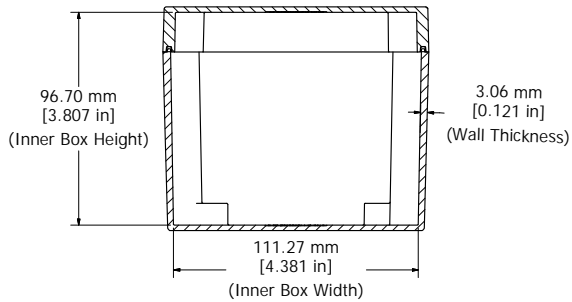
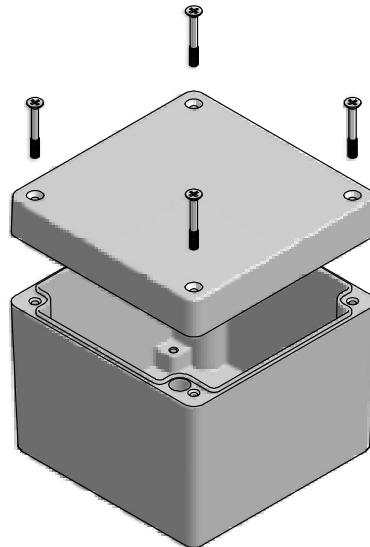
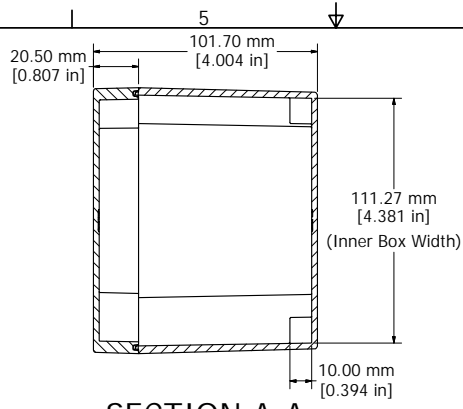
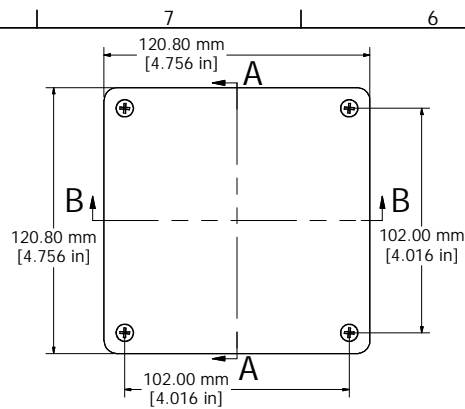

Enclosures can be Factory Modified (Milling, Drilling, Printing etc.)
 Contact Factory mjm@hammondmg.com for quotes
 Solid models of this enclosure available in STEP or IGES.

NOTES	
Purchased assembly includes enclosure, M4x30 lid screws	
Gasket - Pre-formed Silicone Rubber	
Cover screws should be torqued to 5-7.5 lbf.in (50-75 cN.m)	

1550Z137	
PART NUMBERS	
Unfinished	1550Z137
Black Textured Powder Paint - RAL 9011	1550Z137BK



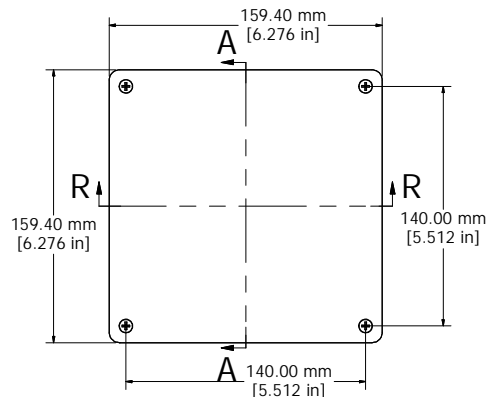

ASSEMBLY

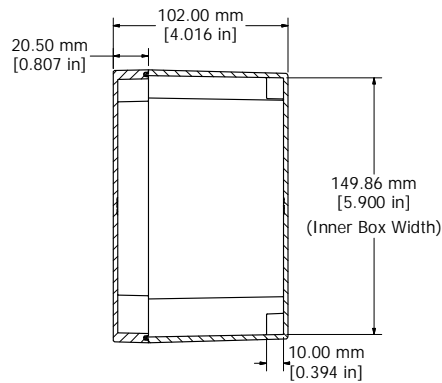

SECTION A-A
End View of Assembly

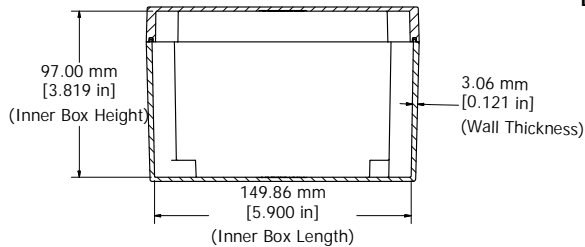
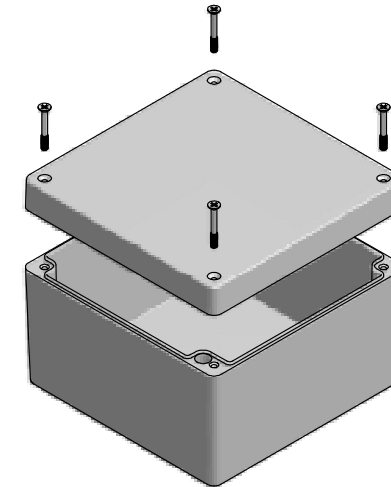

SECTION R-R
Side View of Assembly

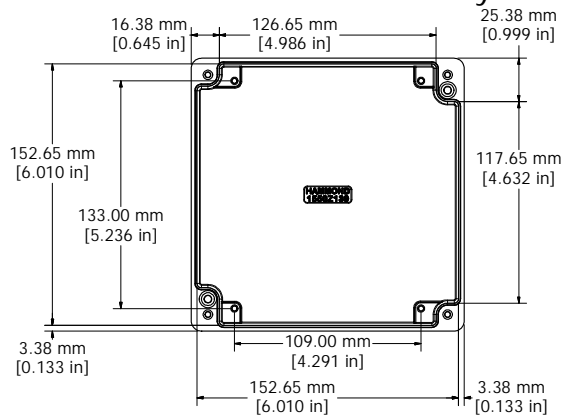

Top View Looking Inside Box

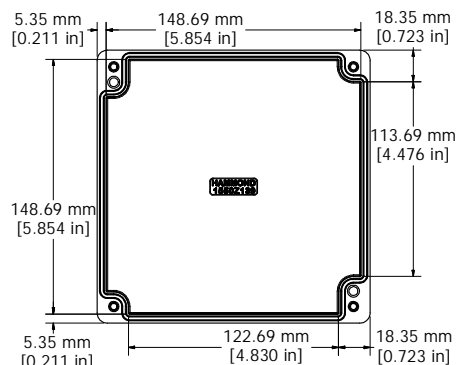

View Looking Inside Lid

Enclosures can be Factory Modified (Milling, Drilling, Printing etc.)
Contact Factory mjm@hammondmfg.com for quotes
Solid models of this enclosure available in STEP or IGES.

NOTES

- Purchased assembly includes enclosure, M4x30 lid screws
- Gasket - Pre-formed Silicone Rubber
- Cover screws should be torqued to 5-7.5 lbf.in (50-75 cN.m)

1550Z139	
PART NUMBERS	
Unfinished	1550Z139
Black Textured Powder Paint - RAL 9011	1550Z139BK

